

# Service Instruction: Tri-Flex Merger Skid Shoe Update

09/14/2015

# **TABLE OF CONTENTS**

<b>Item</b>	<b>Page</b>
Revision Table	3
Tool List	4
Materials List	5
Disassembly Instructions	6-9
Re-assembly Instructions	10-13

*Service Instructions*

**Skid Shoe Update**

<b>Revision</b>	<b>Date</b>	<b>By</b>	<b>Description</b>
1	9/14/15	M. Recla	Initial Release

## Tool List

Tool Number	Quantity	Description	Picture
		Hammer	
		Punches	
		Snap Ring Pliers	
		Torch - As Required for Disassembly	

## Material List

Part Number	Quantity	Description	Picture
71324	1	WLDMT, SHOE BRKT A	
71325	1	WLDMT, SHOE BRKT B	
71062	3	PIN, TFM LONG	
71058	2	PIN, TFM SHORT	
YWFL32010	10	WASHER, FLAT, 1.5X1.0X .070, ZY	
71059	10	SNAP RING, 1.00 X .080, HD	
71138	4	TUBE, RND, 2.00 X 0.5 X .75	
YBPL12015	2	BOLT, PLOW, 1/2-13X1.50, GR5, ZN	
YBCR16010	4	CARR. BOLT, 1/2 X 1-1/2 GR 5, ZN	

## DISASSEMBLY INSTRUCTIONS:

Step 1: Remove Upper Skid Shoe Snap Rings (3G21) on Forward Linkage Pins to Remove (1) Linkage Pin (57468).

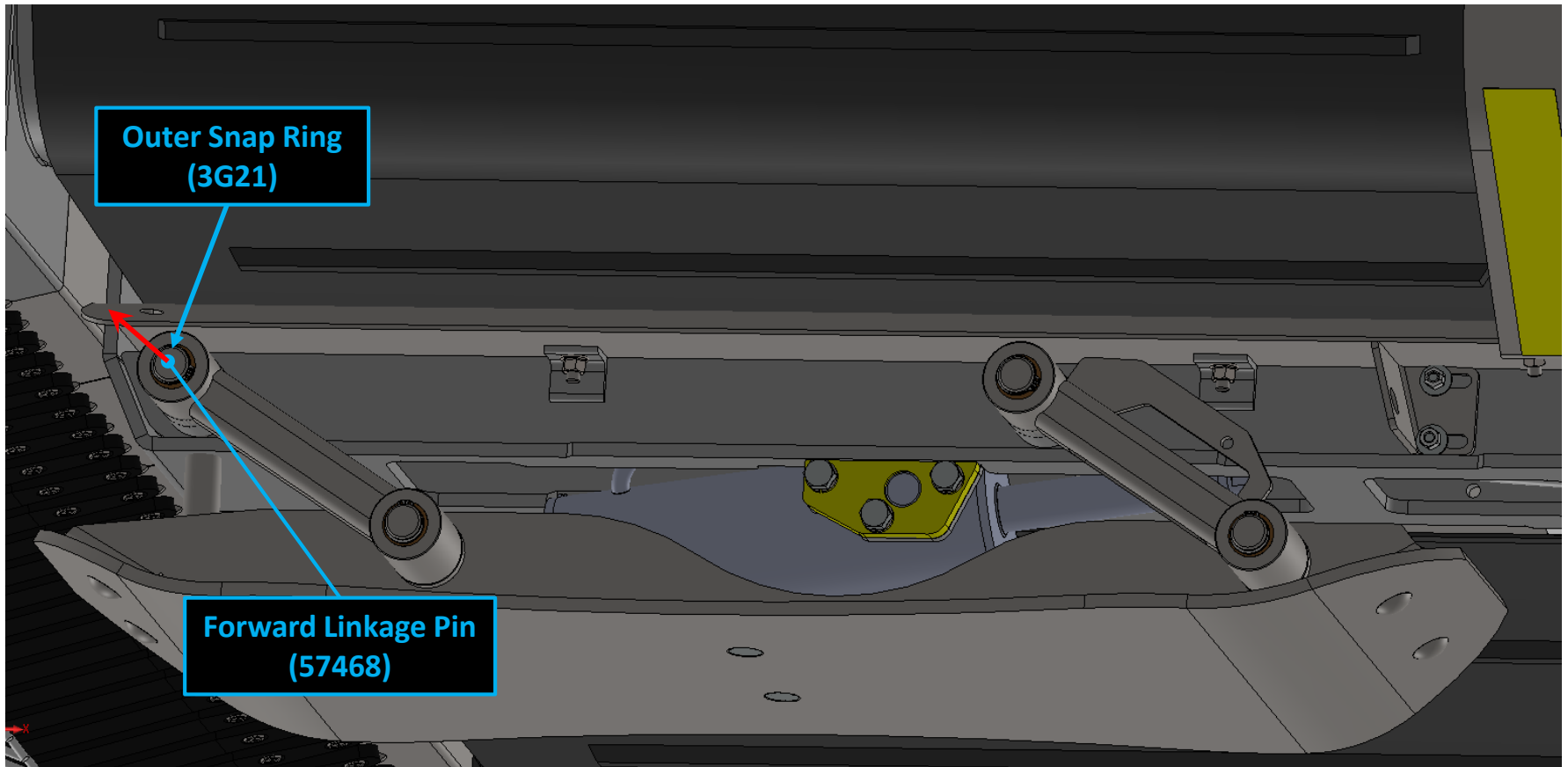

Step 2: Remove Skid Shoe Inner Snap Rings (3G21) on Rear Linkage Pins to Remove Linkage Pins (57469) on both sides of Skid Shoe.

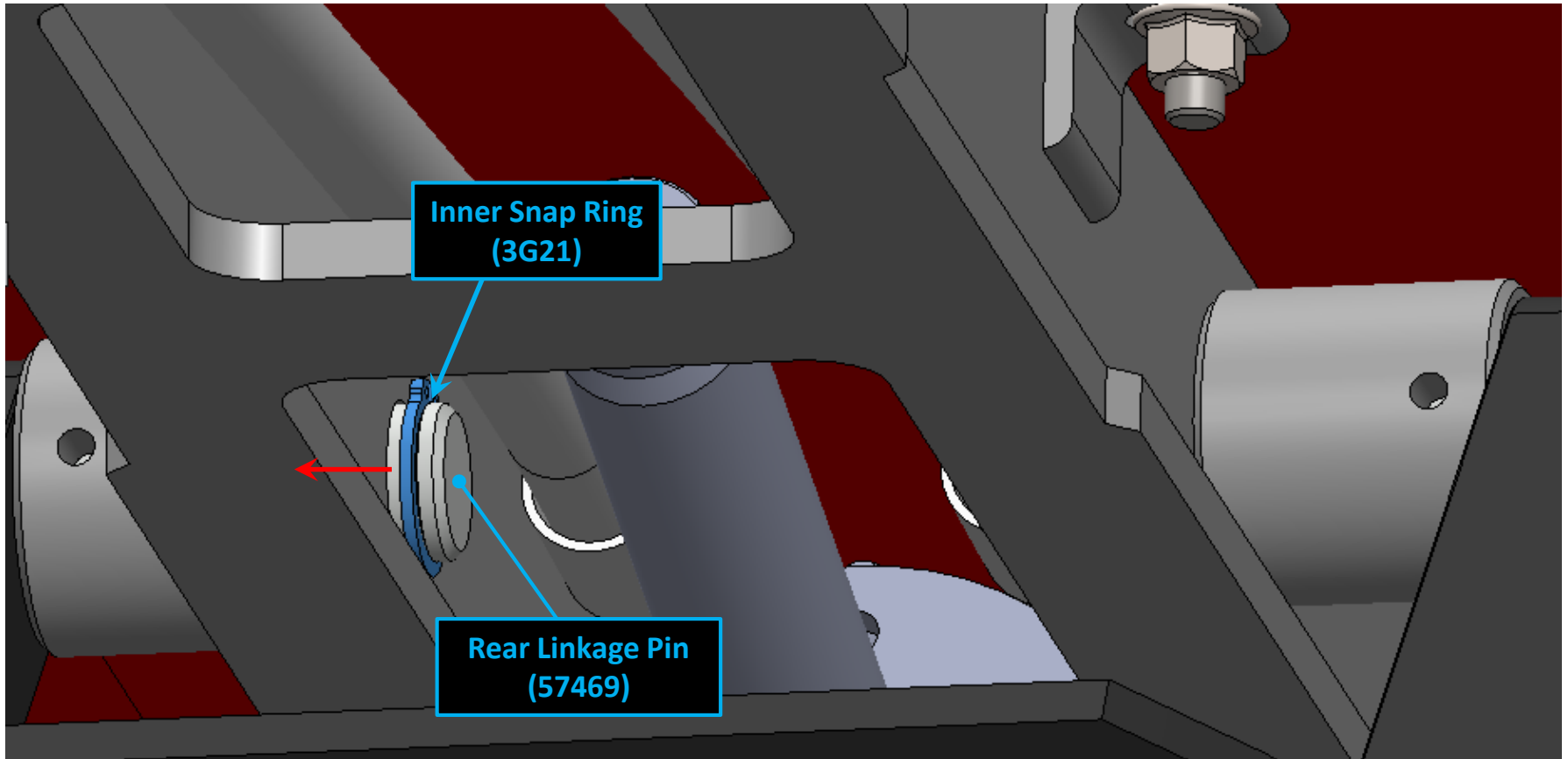

Step 3: Skid Shoe can now be uninstalled from machine. Remove (2) Snap Rings (3G21) to remove the (2) Lower Linkage Pins (57468).

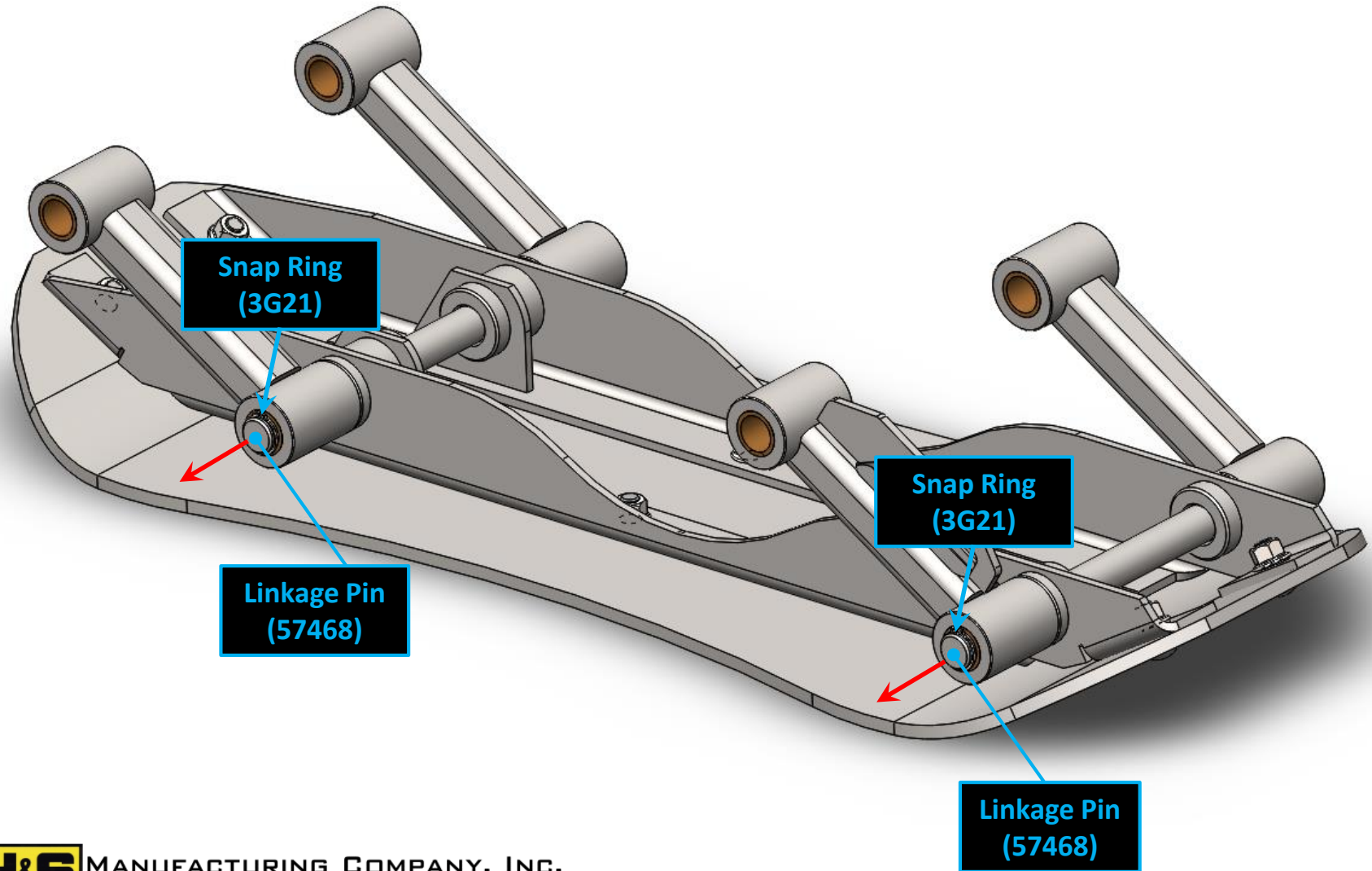



Step 4: Remove (2) existing Skid Shoe Gusset Weldments (63369 & 63370) by removing (4) Carriage Bolts (YBCR16015) and Flange Nuts (YNFG16005) along with (2) Plow Bolts (YBPL16010) and Flange Nuts (YNFG16005).  
{**DISASSEMBLY COMPLETE**}

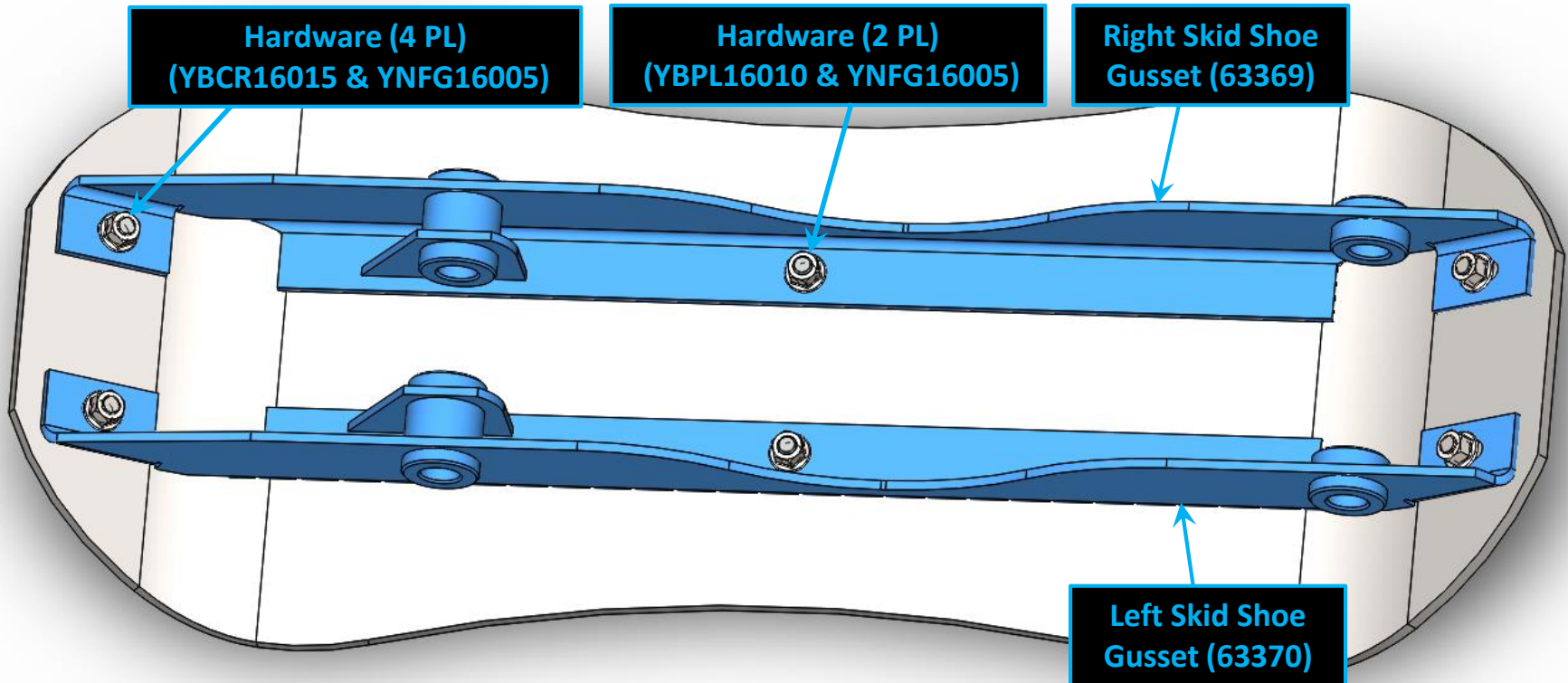

## RE-ASSEMBLY INSTRUCTIONS:

Step 1: Install new Skid Shoe Gusset Weldments (71324 & 71325) using (4) Carriage Bolts (YBCR16010) and Flange Nuts (YNFG16005) along with (2) Plow Bolts (YBPL12015) and Flange Nuts (YNFG16005).

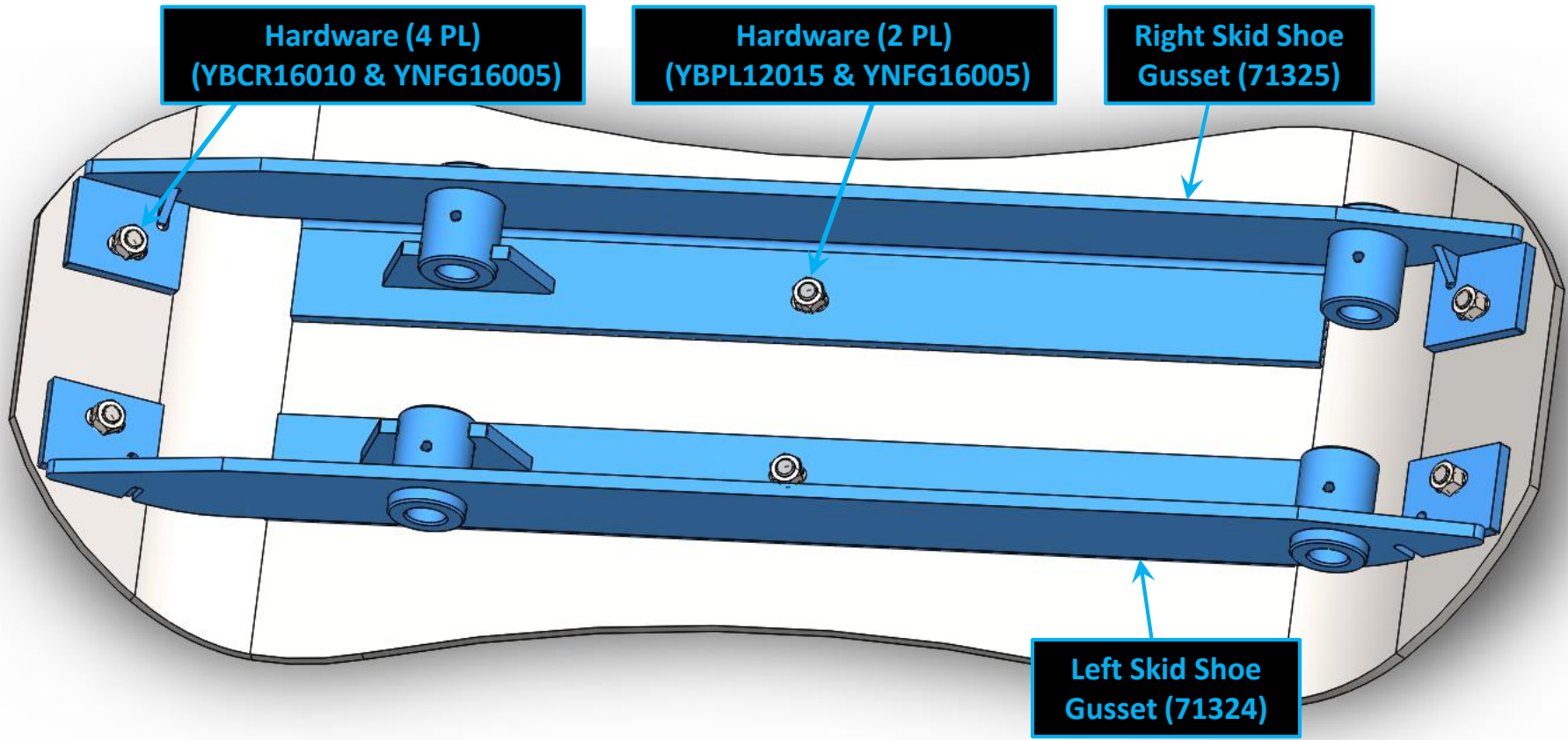

Step 2: Install (2) new Lower Skid Shoe Pins (71062) using (4) Flat Washers (YWFL32010) and (4) Snap Rings (71059).

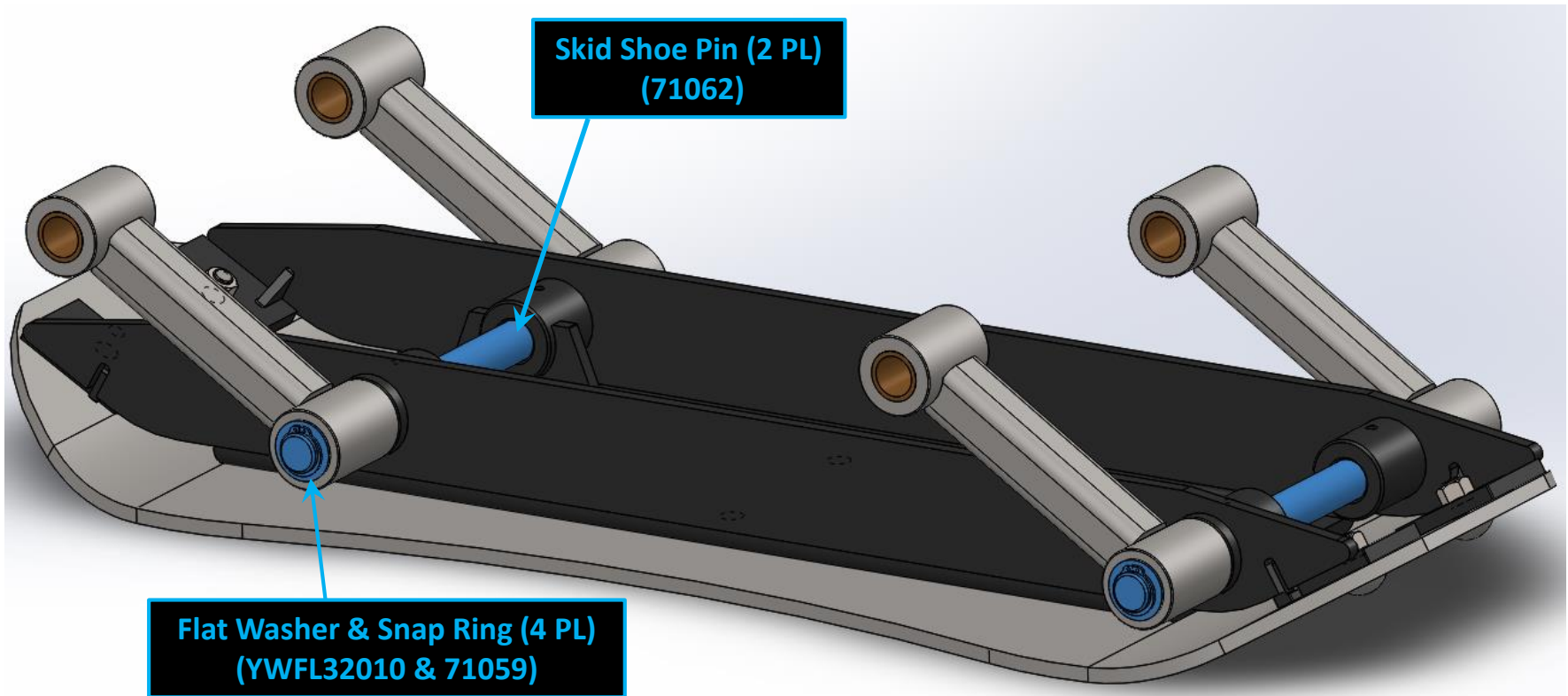

Step 3: Install (1) new Upper Skid Shoe Pins (71062) using (2) Flat Washers (YWFL32010), (2) Snap Rings (71059), and (2) Spacers (71138).

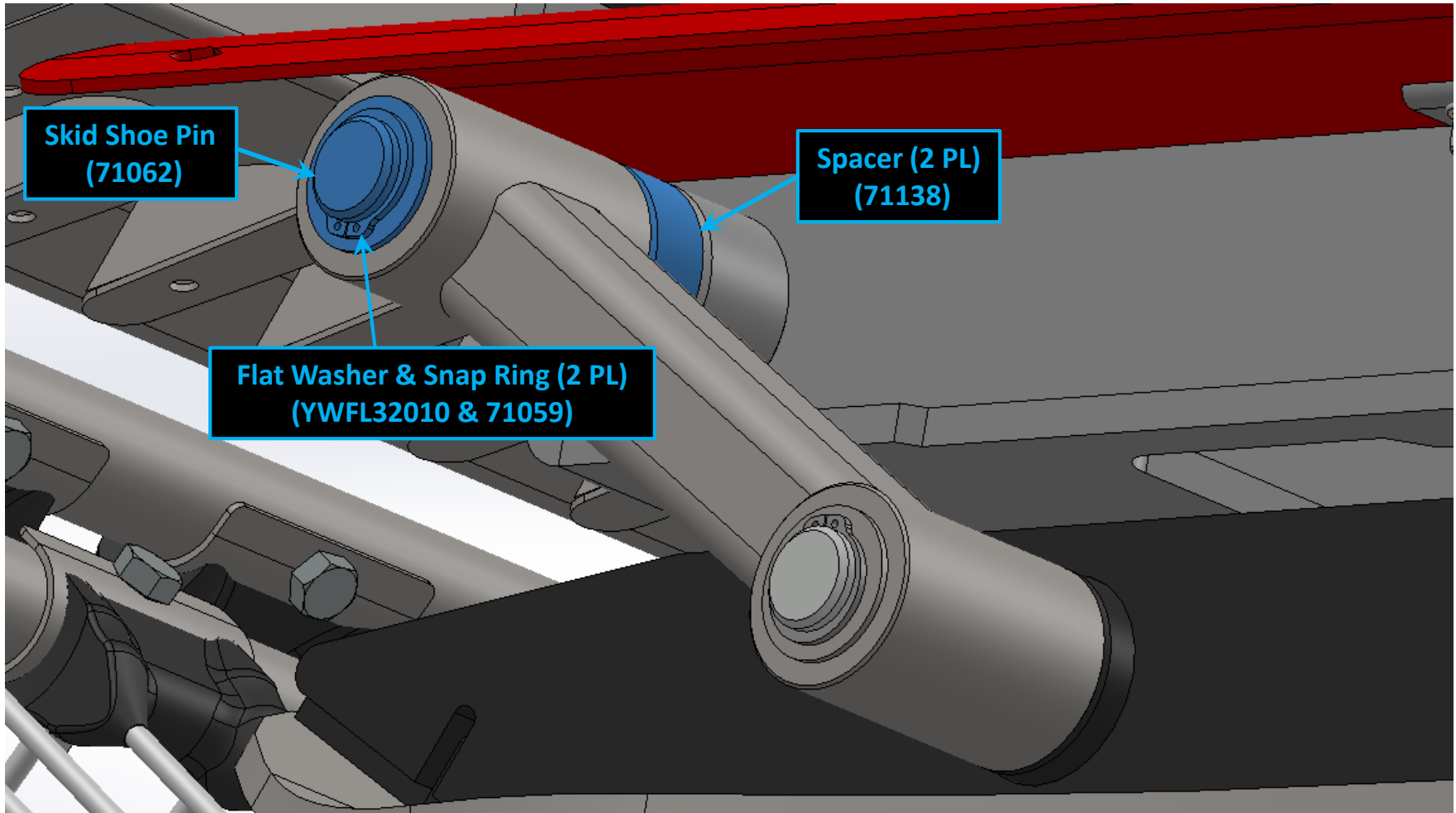

Step 4: Install (2) new Rear Upper Skid Shoe Pins (71058) using (4) Flat Washers (YWFL32010), (4) Snap Rings (71059), and (2) Spacers (71138).

**End of Instruction**

